

# RIVERBEND INSTALLATION

A Tactical Urbanism  
Instruction Manual

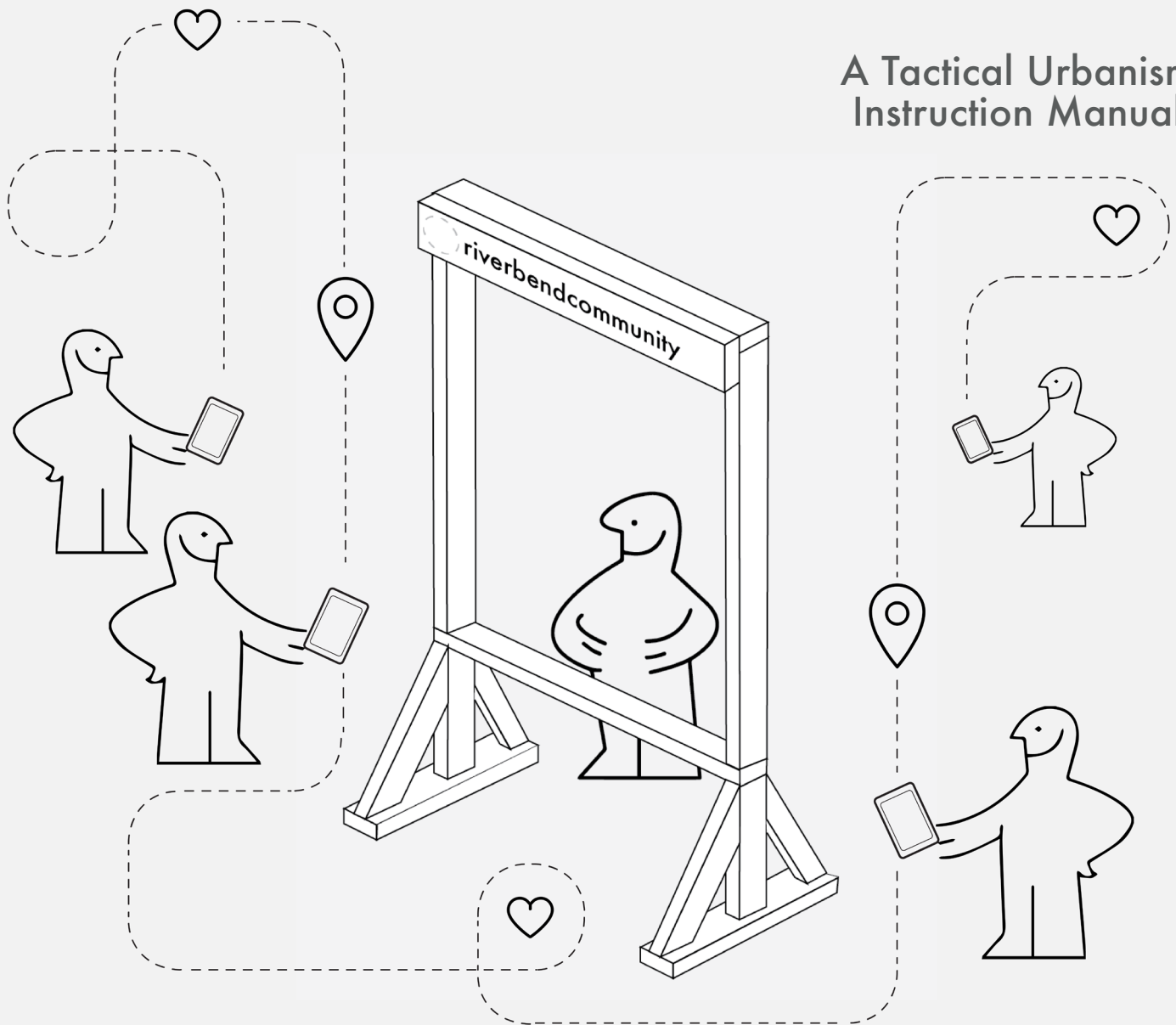

UNIVERSITY OF  
CALGARY



FEDERATION OF  
CALGARY COMMUNITIES

# TABLE OF CONTENTS

WALKING, PLAYING, & BEING NEIGHBOURLY .....	2
OUR TEAM .....	3
WHAT WE HEARD .....	5
PROPOSALS .....	7
INSTA-LLATION .....	8
VALUE TO THE COMMUNITY .....	9
LOCATIONS .....	10
INSTRUCTIONS TO BUILD .....	11
SUGGESTED DESIGNS .....	12
COMMUNITY PARTICIPATION .....	13
TIMELINE .....	14
POLICY .....	14
SCALING UP! .....	15
VERTICAL GARDEN INSTRUCTIONS .....	16
BUDGET .....	17
DISPOSAL .....	18

Thank you to the Riverbend Community Association, The Federation of Calgary Communities, City of Calgary Parks Strategist John Merriman, Dr. Victoria Fast, and the University of Calgary for providing us with the opportunity to do this project!

# WALKING, PLAYING, & BEING NEIGHBOURLY...

## EXPLORING COMMUNITIES: COMMUNITY COLLABS

The Federation of Calgary Communities has partnered with the University of Calgary's Urban Studies Capstone students to bring Tactical Urbanism to four Calgary communities.

The program is designed to engage the communities' board of directors in the identification of opportunities to enhance shared spaces within the neighbourhood. With the help of University of Calgary students, communities will compete for micro-grants to bring a Tactical Urbanism proposal to life.

## WHAT IS TACTICAL URBANISM?

Tactical Urbanism is a temporary, often in-expensive intervention in the built environment intended to improve the experience of visitors to the space. Tactical Urbanism is commonly used in city centres to create spaces for people amidst the concrete, cars, and glass towers. It can also be employed in residential areas such as Riverbend to reclaim and transform under-utilized assets for residents to enjoy.

## ROLE OF THE FEDERATION OF CALGARY COMMUNITIES

The Federation of Calgary Communities supports community associations in building the capacity required to represent residents effectively. The Federation has invited communities to participate in the Community Collabs program in order to demonstrate how small, inexpensive interventions can transform spaces for residents' benefit and enjoyment. The Federation has secured funding for the Community Collabs micro-grants from the Friends of the Federation.

## ROLE OF THE RIVERBEND COMMUNITY ASSOCIATION

The Riverbend Community Association is responsible for the execution of the selected Tactical Urbanism proposal, based upon this final report provided by the student partners from the University of Calgary. Project implementation should occur between April and August, and must be completed by August 31st, 2019.

The Riverbend Community Association will be reimbursed for \$500 in expenses - \$1000 if the proposal wins first place. The success of the project relies upon the skills and generosity of local volunteers.

# OUR TEAM



**EMILY  
REINHART**

Emily has had the privilege of living in several great Canadian cities, though she is happy to call Calgary home. Throughout her undergraduate degree, she has taken a special interest in social policy, and is excited to pursue work in this field following graduation. A believer in the 'housing first' model, Emily hopes to join a local organization to support strategies for ending chronic homelessness in Calgary. In addition to homelessness reduction, she is also passionate about mental health awareness, and she welcomes opportunities to educate herself and volunteer her time to both causes. Emily enjoys cooking as a means of relaxation, and loves sharing the finished product with friends and family. She is looking forward to graduating at the end of the term, and is excited for the adventures that follow.

Justin is a born and raised Calgarian with a strong interest in the future growth of the city. He is currently pursuing a Bachelor of Arts in Urban Studies and minoring in Sociology at the University of Calgary. He has worked on multiple projects exploring how social policy and inequality intersect in an urban environment, and how to use public policy to improve the lives of those living in cities. He also has a breadth of experience from the hospitality industry and has received two nominations for the White Hat Awards, a Calgary-based hospitality and tourism award. Justin is active in the political scene in Alberta and advocates for increased transit infrastructure and affordable housing. In his free time, he enjoys travelling, photography, and going to live music events. He hopes to pursue a graduate degree in Urban Planning or Public Policy Studies and aspires to one day serve as a Calgary City Councillor.



**JUSTIN  
FOLTINEK**



**GRAHAM  
STRATTON**

Born in Seattle, Graham moved to Canada at a young age and was raised in Vancouver. Currently, Graham is in his final year of study at the University of Calgary, majoring in Urban Studies with a minor in Political Science. He has a keen interest in sustainable development and conservation, and the policies and discourse that help support these goals. Applying the knowledge he has acquired in university, Graham hopes to affect change in the urban form, promoting sustainable planning processes and projects that benefit society as a whole. Adept in communication skills and facilitation, Graham has experience leading engagement sessions and consensus building, and brings a collaborative mind to any project he works on. Graham's hobbies of climbing, biking and skiing help fuel his drive for sustainability, drawing inspiration from the outdoors in an effort to preserve it.



**VIVIAN  
TON**

Vivian is a third year student at the University of Calgary, pursuing a Bachelor of Arts in Urban Studies. Currently, she is a research assistant in the Department of Geography under Canada Research Chair Dr. Marit Rosol, whose work focuses on urban food justice. Vivian's study interests include urban political ecology, environmental justice, and public policy. She aspires to complete a design education with a Master's degree in Architecture, informed by her multidisciplinary background in critical urban geography. She aims to create spaces that are radical, sustainable, equitable, accessible, and attractive – being mindful of current and future needs, designing for longevity, and with social and environmental responsibility. Outside of her studies, Vivian is a visual artist and film photographer, and enjoys sharing music with her friends.

Parnian is a Persian-Canadian student graduating from the University of Calgary in Summer 2019. Her love for the urban environment, art and architecture lead her to complete a Bachelor's degree in Urban and Visual Studies. Through her degree, Parnian was able to expand her knowledge regarding city planning and urban development. Her minor degree in visual studies helped to develop her visual creativity and design skills, simultaneously. Parnian has researched multiple urban related issues such as "Impacts of Gender Segregation in Middle Eastern Cities" and collaborated in various academic and non-academic projects. In her free time, she enjoys painting, yoga and going on long walks with her dog, Nefli. Parnian is planning on completing her Masters Degree in Landscape Architecture and working as a registered architect in the future.



**PARNIAN  
NAZEMZADEH**



**RYAN  
AUSTIN**

Ryan is an aspiring architect and designer in Calgary, Alberta. He completed his Diploma in Architectural Technologies at SAIT in 2016, and with this aspired to learn more about the architectural world. Furthering this curiosity, Ryan enrolled in a Bachelor of Arts in Urban Studies at the University of Calgary as well as a Minor in Architectural Studies. With an official acceptance into the Masters of Architecture starting Fall 2019, Ryan hopes to pursue a deeper knowledge on how space and structure can be manipulated to their furthest extent through experimental design. His goal is to create spaces and interactions that force people to look up from their phones and be immersed within a design.

The student group worked closely with the Riverbend Community Association Board of Directors to develop Tactical Urbanism proposals that respond to the needs and goals of the community.

The first meeting with the board provided the students with a valuable insider understanding of Riverbend’s strengths, assets, and challenges. Participatory Mapping and opportunity identification activities engaged board members and generated detailed feedback.

An online survey was distributed to Riverbend residents through the community’s Facebook page. Participants were asked to rate the availability of opportunities for recreational activities, social engagement, enjoying arts and culture, and spending time outdoors. Areas with room for improvement included local arts and culture and overall resident engagement.

At the second board meeting, members were supported in choosing from three Tactical Urbanism proposals. The values and shortcomings of each idea were discussed, and the board was able to come to consensus on the winning proposal.

**2** ENGAGEMENT  
SESSIONS

**77** ONLINE  
SURVEY  
RESPONSES

 **THREE  
PROPOSALS**

# RIVERBEND WHAT WE HEARD



### **PARTICIPATORY MAPPING**

- Board members got to map out locations of interest, areas of improvement, and hidden gems in the community.
- Results showed that many of Riverbend's assets are on the west side, and many in parks.



### **S.N.A.C. ACTIVITY**

- We asked board members to identify types of Social, Natural, Athletic, and Cultural activities they enjoy doing.
- We then asked the board to specify whether or not there were opportunities or not to do these activities in the community, in order to identify potential for growth.

---

### **NATURE & GREEN SPACE**

- Community members expressed their appreciation for Riverbend's parks, green spaces, and wildlife. Carburn Park is a major asset!
- More activities in nature would be appreciated.

### **COMMUNITY ENGAGEMENT**

- Participants commented that while there are a number of community events and programming in Riverbend, they would like to be more involved and engaged.

### **SOCIAL CAPACITY**

- The Riverbend Community Association Board suggested that they would like to build social capacity in the neighbourhood, and explore different social media platforms.

### **ARTS & CULTURE**

- Arts and cultural events seem to be lacking in the Riverbend area; there are opportunities to do something new and interesting to generate community interest.



# PROPOSALS

Taking into consideration everything that was learned through the engagement session with the board and the community-wide survey, three Tactical Urbanism proposals were developed. The three projects each responded to a different area of potential identified by residents, and they varied in terms of length and volunteer capacity. Each proposal aimed to maximize the value to the community within the limits of the \$500 budget.



## PROPOSAL A POP-UP BEACH PARTY

- The idea behind the pop up beach proposal is “We’ll bring the beach, YOU bring the party!”
- The event responds to several requests from residents for a social event geared towards families with young children. Parents are invited to pack up the family for a day at the beach and have fun in the sun with their neighbours.
- The board eliminated the beach proposal because it only offered a single day of community engagement. There were also concerns about poor weather and volunteer capacity.

## PROPOSAL B COLLABORATIVE COMMUNITY MURAL

- The mural proposal is designed to bring a colourful art display to the community centre building, and to engage residents of all ages in a collaborative project to express community pride. Individuals and groups can each paint a square tile at the community paint party, which will later form part of a much bigger mural.
- The RCA Board has previously explored the idea of a permanent community mural. Based on their research, they felt the project couldn’t be executed to their standards for \$500. They also had concerns about volunteer capacity, mural design, and the ongoing maintenance the mural would require to make it last.





## PROPOSAL C

# INSTA-LLATION

INSTA-llation brings elements of art and social engagement to the community, which were identified by residents as areas for growth.

The RCA Board reacted very enthusiastically to the INSTA-llation proposal, and supported it unanimously during the final vote of the consensus-building session. The experiential nature of the project stood out as an attractive feature, and sparked some excellent ideas from the board for further community engagement.

Get residents out and about exploring unfamiliar parts of their neighbourhood.

Harness the power of social media to foster community pride.

Show the rest of Calgary all that Riverbend has to offer!

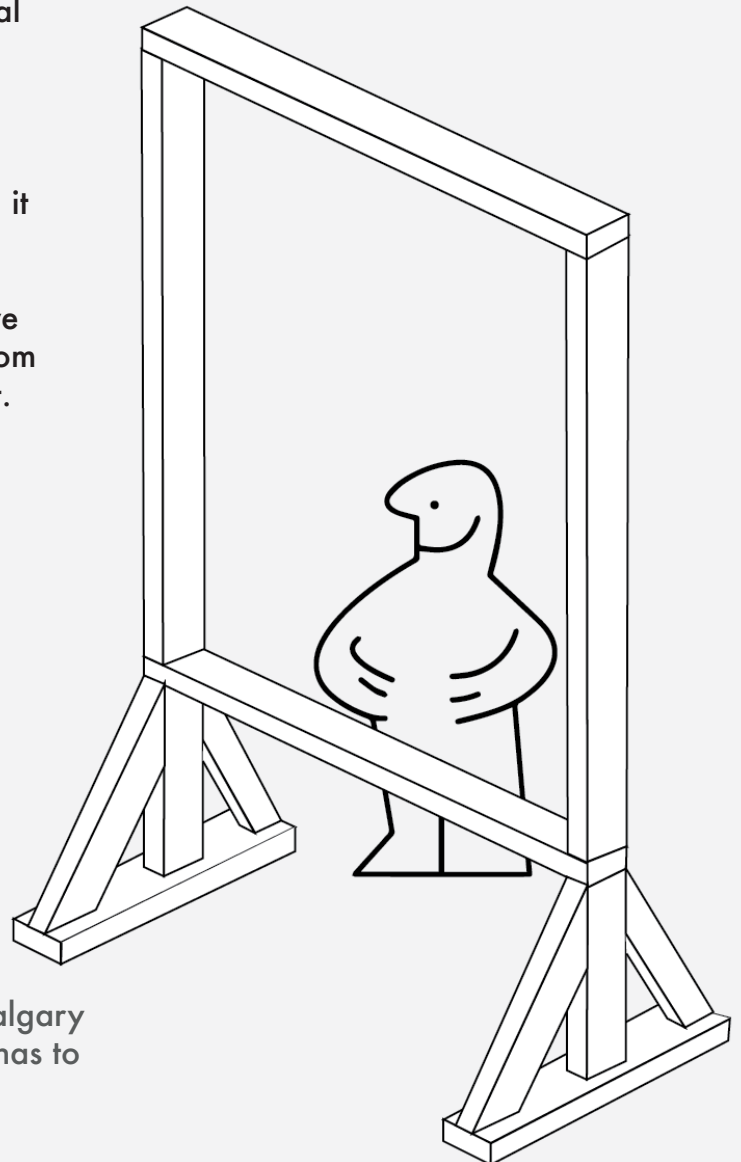

# VALUE TO THE COMMUNITY

Much of the value of INSTA-llation comes at no additional cost to the community. Beyond the expenses associated with constructing and decorating the frames, INSTA-llation provides lasting social benefits. These include the fostering of a renewed sense of community pride and increased awareness of the neighbourhood's best qualities – it's residents. Community members can express their creativity both through the creation of these temporary art installations and their photographs with the frames.

The project also addresses some of the board's goals for the community and community association. INSTA-llation harnesses the preferred means of interaction for many people - social media - to unite them through shared experiences. The Riverbend Community Association already manages very successful Facebook and Twitter accounts, but has yet to establish a community hashtag for use across the various social media platforms. The INSTA-llation project presents the opportunity to launch one or more community hashtags, allowing photos of the community to be tracked and linked back to Riverbend. The hashtag will be instrumental in boosting the community's following on social media.

The proposed locations for the INSTA-llation frames are park spaces which are frequented by Riverbend residents as well as visitors from throughout Calgary. The interactive enjoyment of these pieces of art will extend beyond Riverbend as images are shared on social media platforms. This may in turn draw others to visit Riverbend, increasing awareness of the community's vibrance and many assets.



**SITE A:**

**CARBURN PARK LAGOON**

<https://goo.gl/maps/gHHJqJZ8Zw>



**LOCATIONS  
LOCATIONS  
LOCATIONS  
RIVERBEND**

**SITE C:**

**BOW RIVER PATHWAY**

<https://goo.gl/maps/2DjogyFufiH2>



**SITE B:**

**RIVERSTONE PARK**

<https://goo.gl/maps/jaFFpvdPePH2>

# INSTALLÄTION

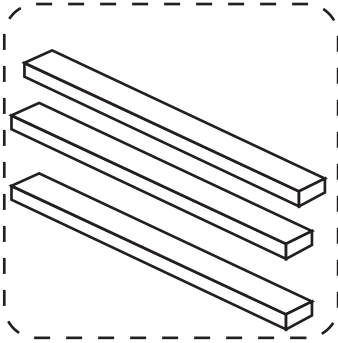
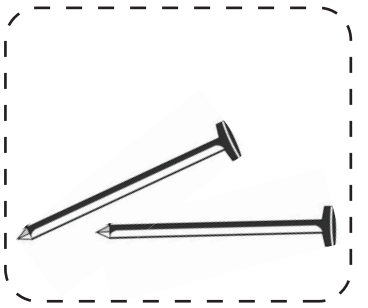
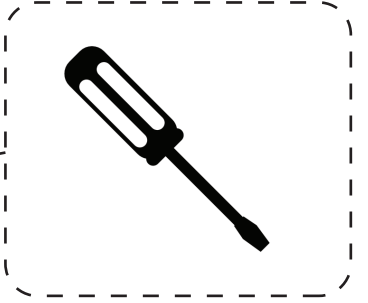
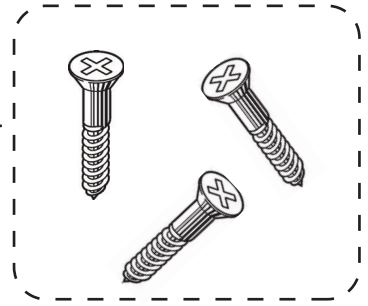
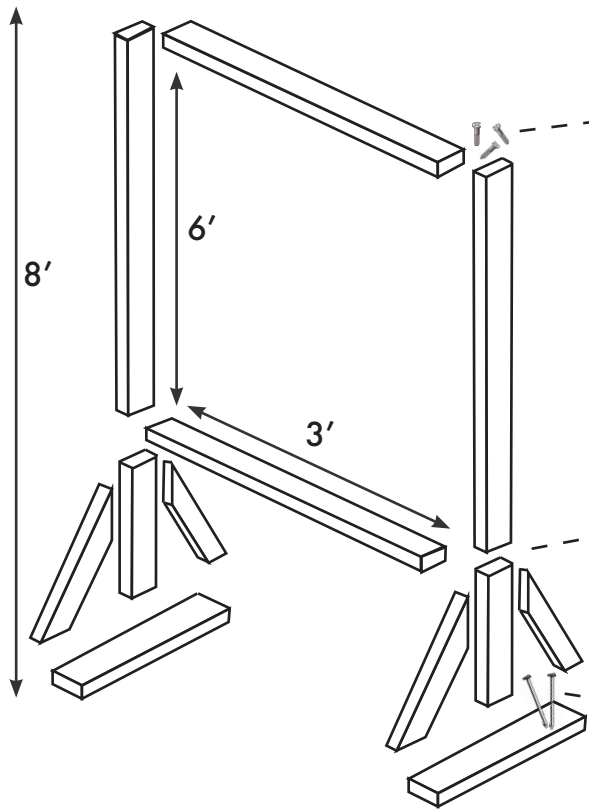

1.

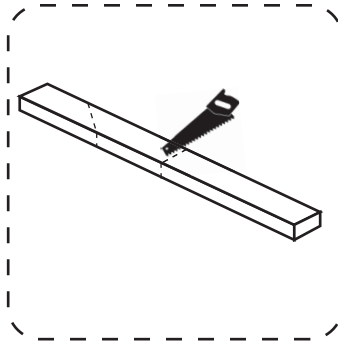

2.

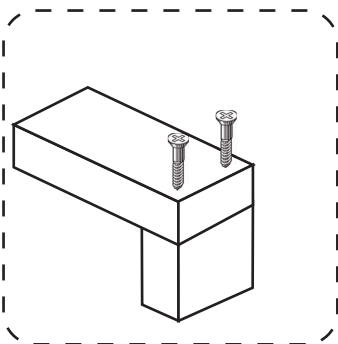

3.

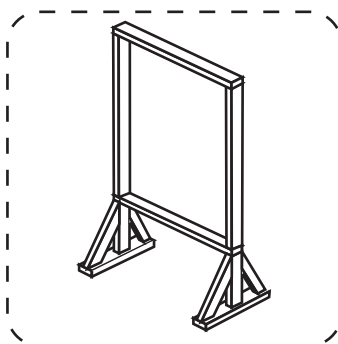

4.

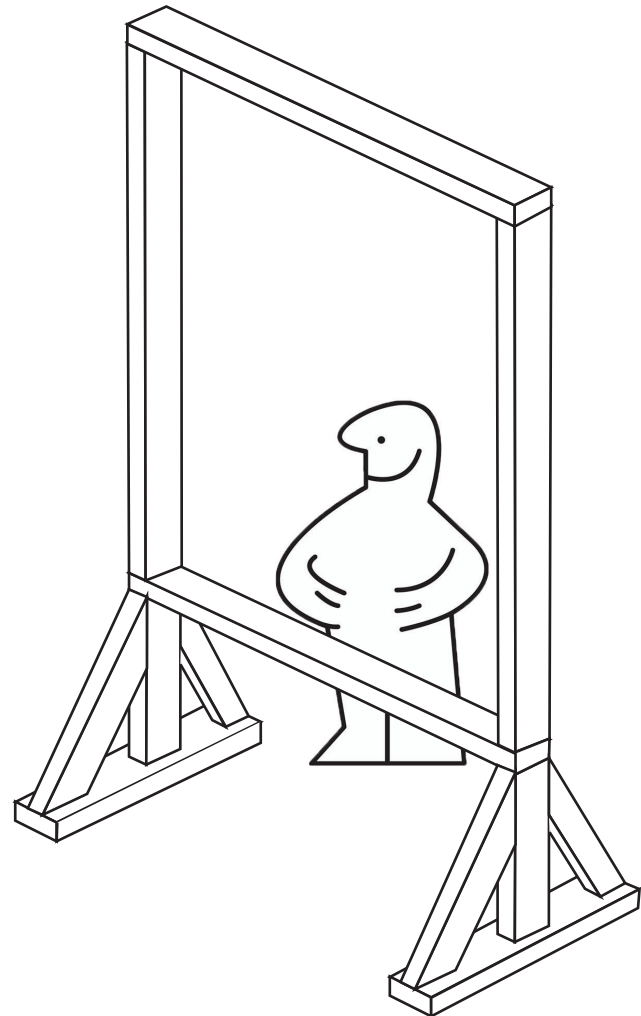



# SUGGESTED DESIGNS

Need some design inspiration?  
Here are a couple of decoration ideas to get you started.

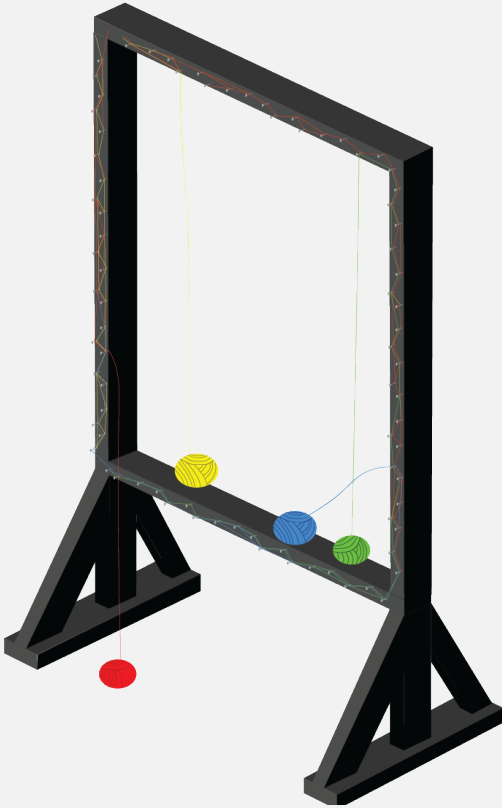

## YARN BOMB

- Attach nails around the frame.
- Leave a variety of coloured yarns and strings for users to wrap around the nails and frame.
- Interactive!

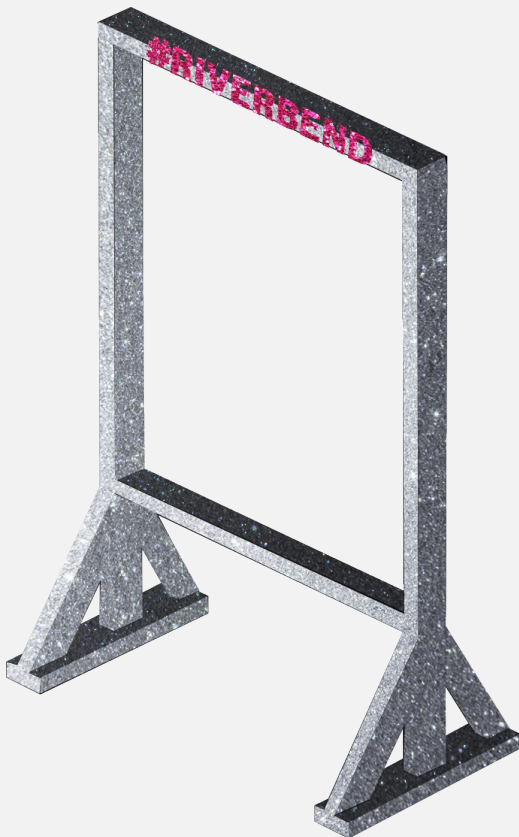

## NEON GLOW

- Bold, bright, and eye-catching.
- Spray paint the entire frame with fluorescent, neon, or glow-in-the-dark paint. Use stencil to spray paint community #hashtag all over.

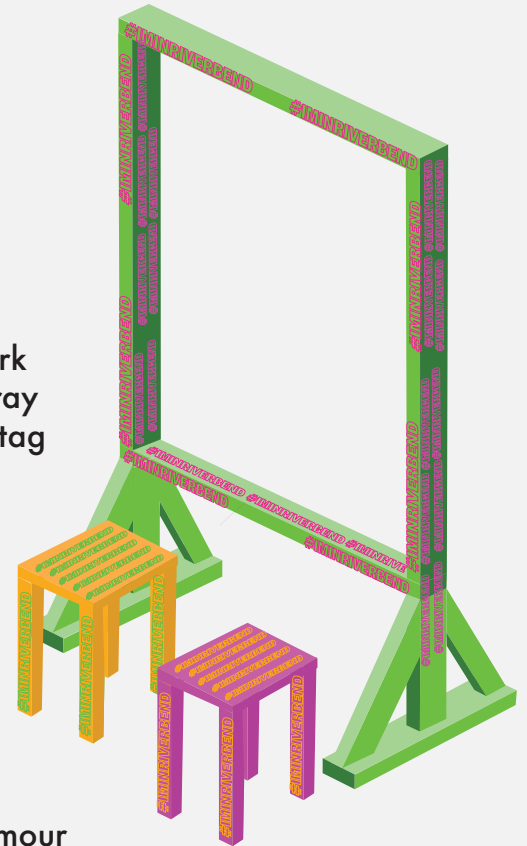

## GLITTER

- Get ready for your glamour shot! This frame is all sparkle and shine.
- Use a weatherproof glitter acrylic paint, or adhesive vinyl sheets to cover the frame (this method is advised – better for the environment).

# COMMUNITY PARTICIPATION

## CALL FOR ARTISTS

The Community Association may choose to seek out local artists to propose and execute designs for the INSTA-llation frames. The job may be awarded to individuals, families, teams, or clubs who present a winning design.

## CREATE A HASHTAG

Have a contest to see which resident can come up with the most creative Riverbend hashtag. Have Facebook followers vote and reward the winner with a prize.

## SURPRISE THE COMMUNITY

Announce the installation of the frames but withhold their locations. Residents will have to get out and about to find them.

## SHARE RIVERBEND'S STORY

Include facts or stories about the neighbourhood's history on the back side or base of each frame. Residents will learn something new about the community they love.

## SCAVENGER HUNT

Integrate clues into each frame that fit together to form a message. Reward the first to solve the puzzle with a prize or free annual membership.

# POLICY

Parks Community Strategist John Merriman of the City of Calgary was instrumental in determining the appropriate locations for INSTA-llation frames. Mr. Merriman had the three proposed locations approved by the South Calgary Zone Superintendent and Parks Ecologist. The locations minimize the frames' impact on the environment, as well as any disruption to the regular maintenance of park spaces.

No permits are required for this project, but Mr. Merriman indicated that the Riverbend Community Association must accept full responsibility and liability for the frames. The proposed design and installation of the frames take into consideration the safety of users and community members. Frames will be secured to the ground to prevent accident or injury.

# TIMELINE

## 1<sup>ST</sup> PHASE (THREE WEEKS)

The first phase of the project involves two volunteers gathering supplies for the project, and putting out the call for designs. Some tools are also needed for the construction of the frames by donation from the community and should be gathered at this time.

## 3<sup>RD</sup> PHASE (TWO WEEKS)

After the base frame construction, the RCA will have two weeks to decorate the frames, although the number of volunteers needed for this phase is dependent on the complexity of the designs.

## 2<sup>ND</sup> PHASE (ONE WEEK)

The second phase of the project requires two carpentry savvy volunteers for the construction of the base frames. This is estimated to take roughly four hours of work, and we have allocated one week for this task.

## 4<sup>TH</sup> PHASE (ONE WEEK)

Finally, the signs need to be installed and secured to their locations. We think this will take two volunteers for two hours' work, with a week allocated to arrange the logistics of moving frames.

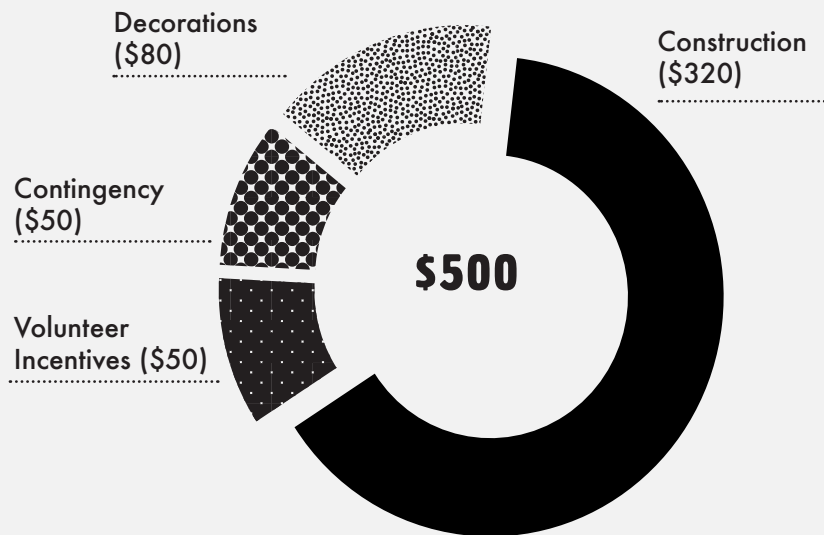

See full budget on page 18.



# SCALING UP!

The proposed INSTA-llations offer a unique experience to community members of all ages, and maximize the impact of the \$500 budget. The grand prize of \$1000 would allow the community to build an additional INSTA-llation that is bigger and better than the rest! How about a Vertical Garden, complete with turf, flowers, and twinkling lights?

Construction of the Vertical Garden INSTA-llation follows a similar design to the other three frames. It requires a wider base, however, to fit a 4-foot by 8-foot sheet of oriented strand board (OSB). This board will run right to the ground, and will be covered by inexpensive astroturf squares. The backdrop can then be embellished with paint, silk flowers, lighting, and lettering to the decorator's liking.

Placing this backdrop in a high-traffic area at the Riverbend Community Centre means community members can enjoy it as they come and go from daycare, recreational and social programming, and meetings. Hall renters will love the added bonus of the Vertical Garden too. It's perfect for weddings, baby showers, and other special events.

The Vertical Garden backdrop should be weighted down with sandbags and positioned out of the wind to avoid gusts. The community can reduce the risk of vandalism or theft by placing this INSTA-llation in a well-lit area at the community centre. This allows greater flexibility in materials and the incorporation of elements like solar-powered lights.

The extra \$500 of the bonus prize includes funds for upgrading the three INSTA-llations from our original proposal.

Money has been set aside to upgrade the frames from lumber to treated wood, which would increase the lifespan and quality of the bases. We have also allocated extra funds to the décor budget for the three smaller frames.

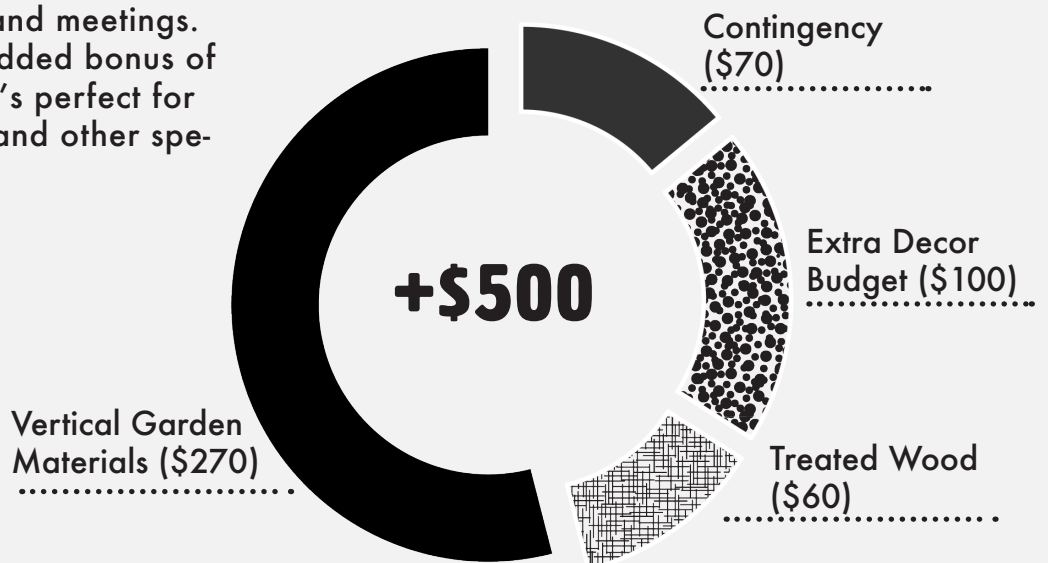

See full budget on page 19.

# TURF WÄLL

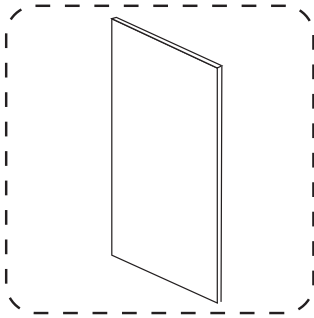
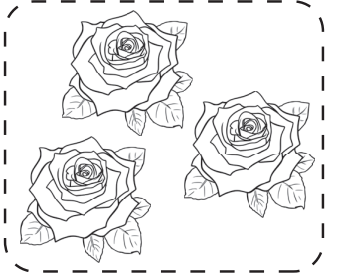
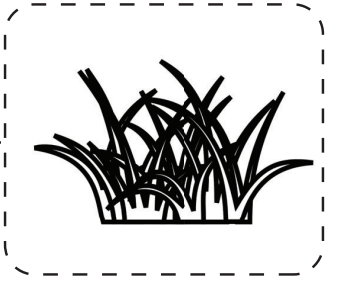
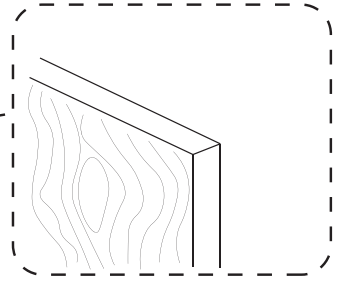
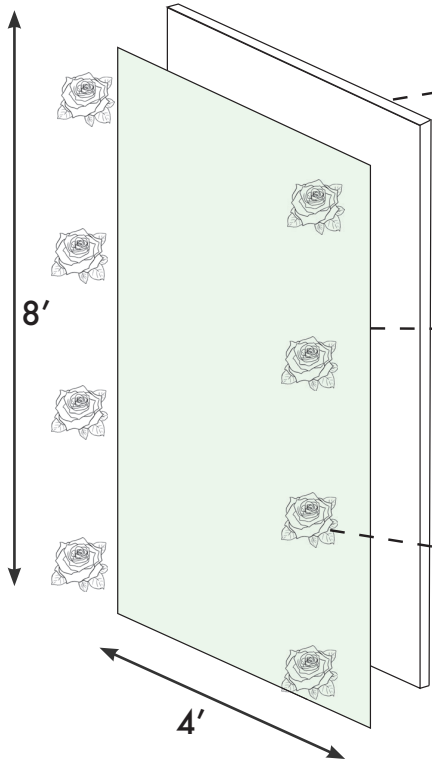

1.

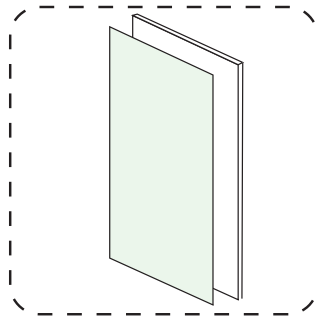

2.

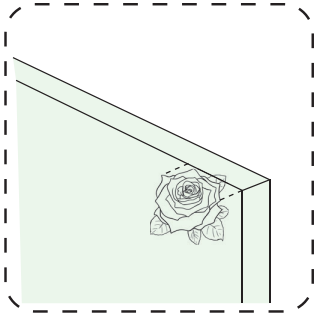

3.

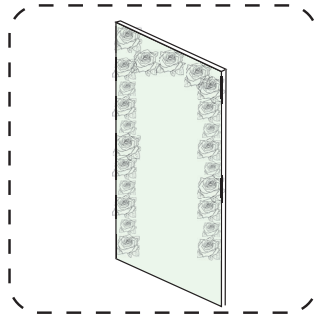

4.

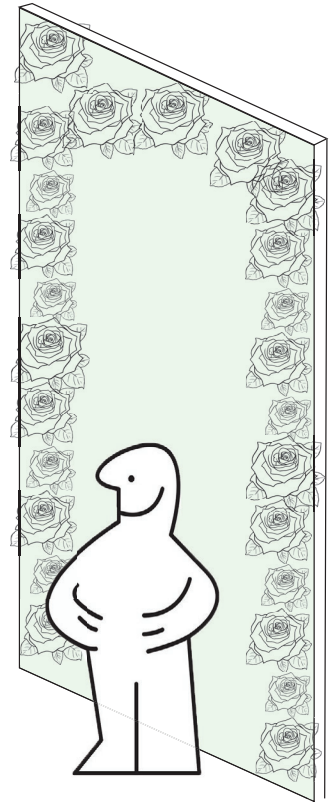

# INSTA-LLATION BUDGET

	Quantity	Cost per unit	Total
<b>FRAME, individual</b>			
<b>Frame Base</b>			<b>24.85</b>
Lumber (2"x4"x8' SPF Dimension Lumber)	7.0	3.55	24.85
<b>Frame</b>			<b>28.92</b>
Lumber (1"x4"x12' Spruce)	2.0	5.46	10.92
Spray Paint (per can)	1.5	12.00	18.00
<b>Decor (to be decided by community)</b>			<b>48.50</b>
<b>Installation</b>			<b>14.70</b>
Anchoring Spikes, 8 inch	5.0	2.94	14.70
<b>Disposal (community dumpster for components that can't be repurposed)</b>		<b>Donated</b>	<b>0.00</b>
		<b>Subtotal</b>	<b>116.97</b>
		<b>GST</b>	<b>5.85</b>
		<b>Total Cost Per Frame</b>	<b>122.82</b>
<b>FRAME, total</b>			
<b>Frames</b>	<b>3.0</b>	<b>122.82</b>	<b>368.46</b>
<b>SHARED COST</b>			
<b>Tools and Materials</b>			<b>24.86</b>
Miter Saw	1.0	Donated	0.00
Drill and Drill Bits	2.0	Donated	0.00
Hammers	2.0	Donated	0.00
Nails, 2 1/4" common bright, box of 50	2.0	4.69	9.38
Glue Gun + 10 Mini Glue Sticks, package	1.0	6.50	6.50
Glue Sticks, pack of 15	1.0	4.99	4.99
Dust Mask, pack of 5	1.0	3.99	3.99
Garbage Bags, large	5.0	Donated	0.00
<b>Execution</b>		<b>Donated</b>	<b>0.00</b>
Transportation, pick-up truck		Donated	0.00
<b>Workshop Space (inside, outside Riverbend Community Centre)</b>		<b>Donated</b>	<b>0.00</b>
Construction	4 hrs	0.00	0.00
Decor	10 hrs	0.00	0.00
<b>Volunteers</b>		<b>Donated</b>	<b>0.00</b>
Final Arrangements with City Park	One person	3 hrs at \$0/hr	0.00
Material Purchasing	One person	2 hrs at \$0/hr	0.00
Construction/Assembly	Two people	4 hrs at \$0/hr	0.00
Decoration (selecting materials, design, painting, decor)	Three people	10 hrs at \$0/hr	0.00
Installation	Two people	2 hrs at \$0/hr	0.00
<b>Volunteer Incentive</b>	<b>1.0</b>	<b>50.00</b>	<b>50.00</b>
		<b>Subtotal</b>	<b>74.86</b>
		<b>GST (5%)</b>	<b>3.74</b>
		<b>Total</b>	<b>78.60</b>
<b>CONTINGENCY (10% of allotted budget)</b>			<b>50.00</b>
<b>PROJECT TOTAL</b>			<b>497.06</b>

# SCALE-UP BUDGET

<b>SCALE-UP</b>			
<b>Upgrade to Treated Wood</b>	<b>3.0</b>	<b>20.00</b>	<b>60.00</b>
<b>Additional Decor for Frames</b>			<b>100.00</b>
<b>Additional Turf Wall Frame at Community Centre</b>			<b>266.00</b>
Base Frame	1.0	24.85	24.85
Oriented Strand Board, 7/16" x 4' x 8'	1.0	11.98	12.98
Sand Bags, 18 kg traction sand	2.0	7.2	14.40
Astro Turf (per pack of 9 x 1 sq. ft. tiles)	2.0	44.99	89.98
Nails (1 1/2" finishing bright, 150 g box)	1.0	3.80	3.80
Lights (Solar LED Fairy Light, 21 ft)	1.0	11.99	11.99
Wooden Letters (estimate)	12.0	3.00	36.00
Spray Paint (per can)	1.0	12.00	12.00
Decor (to be decided by community)			60.00
		<b>Subtotal</b>	<b>426.00</b>
		<b>GST (5%)</b>	<b>21.30</b>
		<b>Scale Up Total</b>	<b>447.30</b>
<b>SCALE-UP CONTINGENCY (10% of scale-up budget)</b>			<b>50.00</b>
<b>SCALE-UP TOTAL</b>			<b>497.30</b>

# DISPOSAL

The Riverbend Community Association is encouraged to reuse, repurpose, or recycle as many components of the INSTA-llation frames as possible, to minimize the waste and environmental impact generated by this project. As a temporary and non-intrusive tactical urbanism project, INSTA-llation allows for the selected sites to return to their former state without any lasting effects.



